

MARKET LEADERS IN FILTRATION

CARLSON SHEETS

XE RANGE

Filter

The XE range comprises a comprehensive series of high performance filter sheets designed to meet the needs of a range of specialist applications.



FEATURES

- XE filtration sheets are widely used in the filtration of products where they give outstanding clarity and stability combined with long sheet life and integrity
- Edge leakage is reduced to a minimum because of the special XE filter sheet formulation and processing conditions
- All XE products are made to the same carefully controlled thickness specifications so that the different grades can be used in the same filter press configuration and seal thickness
- The XE range of products is comprised of a comprehensive series of high performance filter sheets, with raw materials specially selected to ensure compatibility with food beverage and pharmaceutical industries
- All XE range filter sheets incorporate an advanced blend of selected and processed bleached cellulose fibres combined with non-hazardous filter-aids and approved resins to produce filter media with superior filtration capabilities, along with excellent wet and dry handling

APPLICATIONS FOR PRODUCT

- Typical applications include spirits, wines, beers and lagers where long life, sterility, stability and clarity are essential
- XE products have found wide acceptance in the filtration of syrups for soft drinks, gelatines and cosmetics
- A diverse spread of chemical and pharmaceutical intermediates and final products

OPERATING CONDITIONS

When inserting into the filter press handle with care to eliminate distortion or abrasion. Never use a damaged filter sheet.

Sheets should be stored in their original packaging in an odourless, dry and ventilated environment. We recommend using the filter sheets within 36 months after purchase.

To ensure correct use place the smooth side of the filter sheet against the filtration plate (i.e. downstream). The rough side of the filter sheet faces the liquid to be filtered.

STERILIZATION:

Steam:	134°C, 20 min
Hot Water:	80-85°C, 20 min
Storage:	Dry, cool and free from strong odours

MATERIALS OF CONSTRUCTION

All XE filter sheets incorporate an advanced blend of selected and processed bleached cellulose fibres combined with non-hazardous filter-aids and approved resins to produce filter media with superior filtration capabilities.

MEASUREMENTS

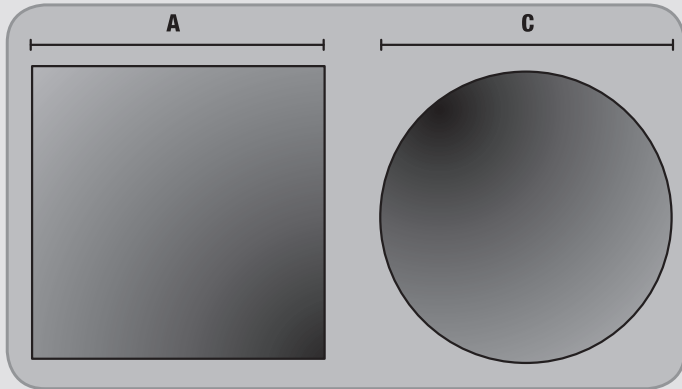

A = LENGTH C = DIAMETER (cm)

PLATE & FRAME FILTRATION

NOTE: Custom sizes are available.
Please contact our office.

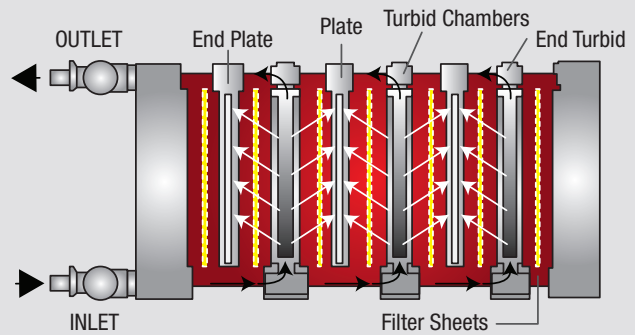

DRIP LOSS CHANGES % LOSS

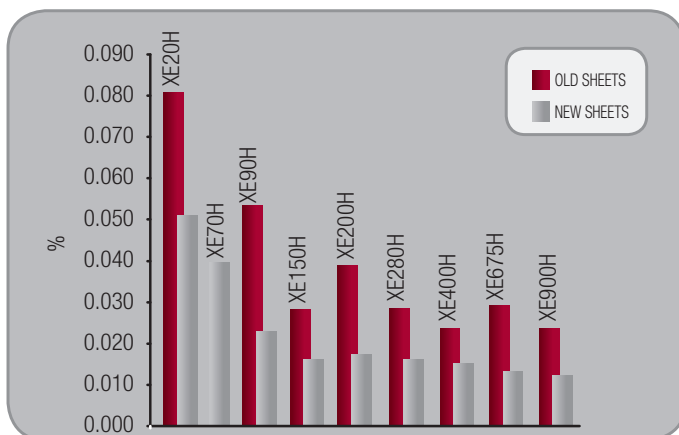

PHYSICAL DATA

TEST PROPERTIES UNITS	BASIC WEIGHT G/M ²	THICKNESS MM (B)	% ASH CONTENT % WEIGHT (G)	FLOW RATE	
				LITRES/MIN/M ² @1 BAR	LITRES/MIN/M ² @0.3 BAR
XE1700H	1450	3.8	50	24	
XE1200H	1400	3.8	50	47	
XE900H	1375	3.75	50	60	
XE675H	1375	3.75	50	80	
XE400H	1325	3.75	44	150	
XE280H	1290	3.75	44	193	
XE200H	1265	3.75	42	270	
XE150H	1235	3.75	42	373	
XE90H	1190	3.75	42	448	
XE70H	1140	3.75	38	600	
XE50H	1150	3.75	38	685	
XE20H	1050	3.75	25	1098	
XE10H	1040	3.75	18	1308	
XE5	790	3.6	1		2280

ORDERING INFORMATION

RANGE	GRADE	/A (cm)	/C
203-XE	5	20 (20x20)	22R
	10	40 (40x40)	30R
	20	60 (60x61.4)	42R
	50	Example: 203-XE40/40 SQUARE SHEET	Example: 203-XE40/22R ROUND SHEET
	90		
	150		
	200		
	280		
	400		
	675		
	900		
	1200		
	1700		

GENERAL INFORMATION

GRADE	NOMINAL MICRON	FILTRATION LEVEL
5	10.5-25	COARSE CLARIFYING
10	9-22	COARSE CLARIFYING
20	8-20	COARSE CLARIFYING
50	6-15	COARSE CLARIFYING
90	4-9	MEDIUM CLARIFYING
150	3.0-7.0	MEDIUM CLARIFYING
200	1.0-3.0	FINE CLARIFYING
280	0.5-1.5	FINE CLARIFYING
400	0.5-0.8	FINE CLARIFYING
675	0.4-0.6	STERILIZING
900	0.4-0.5	STERILIZING
1200	0.2-0.4	STERILIZING
1700	0.1-0.2	STERILIZING

Australia Office:

P: +61 (0) 3 9872 6811
 F: +61 (0) 3 9872 6822
 E: Feedback@progressivegroup.com.au
 17 Redland Drive, Mitcham, 3132, Victoria, Australia
 www.progressivegroup.com.au

New Zealand Office:

P: +64 (0) 9 951 3142
 F: +64 (0) 9 951 3143
 E: Feedback@progressivegroupnz.co.nz
 17B Farnham Street, Parnell, Auckland, 1052, New Zealand
 www.progressivegroupnz.co.nz